

## DP Product (Dual Purpose Drive)

Bernardo Sainz<sup>1</sup>, Rommel Villarreal<sup>2</sup>, Christopher Uliana<sup>3</sup>

<sup>1</sup>AMI Automation

Boulevard Gustavo Diaz Ordaz 402, Nuevo Leon, Mexico, 64650 Phone: +52-81-1001-4050  
Email: bernardo.sainz@amiautomation.com

<sup>2</sup>AMI Automation

Boulevard Gustavo Diaz Ordaz 402, Nuevo Leon, Mexico, 64650 Phone: +52-81-1001-4050  
Email: rommel.villarreal@amiautomation.com

<sup>3</sup>TMEIC Corporation

2080 Cook Drive, Salem, VA, 24153  
1325 Electric Road, Roanoke, VA, 24018  
Phone: +1 540 2832090  
Email: christopher.uliana@tmeic.com

Key Words: Gradual modernization, cost reduction

## INTRODUCTION

Upgrading the direct current Drive and Motor System to the more modern alternate current (AC) technology requires high levels of investment and extended shutdown times. Partially postponing or updating systems involves changes throughout the energy conversion device chain (drives, motors, installation, etc.). Nowadays, an option exists which makes it possible to upgrade while taking advantage of new drive technologies, by using an inverter for induction motors programmed to energize a DC motor. The new dual purpose drive technology helps facilitate upgrade by allowing replacement of only the DC drives with standard AC inverters, while reusing the remaining system components such as motors, wiring, instruments, etc. This makes it possible to prevent system obsolescence without sacrificing the upgrade to AC technology, in more appropriate shutdown times and with gradual replacement of induction motors according to the capital and line stoppage budgets.

## DISCUSSION

### Problem description

The main issues arising from electrical equipment upgrade are costs and time. This could even discourage an investment towards renovations and lead to obsolescence issues being ignored year after year. Upgrading to state-of-the-art drive technology involves important modifications which could even require civil works. Below is a table comparing the upgrade to AC technology and the replacement of DC drives.

TASK	UPGRADE TO AC	UPGRADE OF DC DRIVES ONLY
New Transformer	Possible	NO
New Drive	YES	YES
Motor Change	YES	NO
Others		

Inactivity leads to money and time losses, and current market conditions deem it very hard to increase shutdown times for repairs or commissioning of upgrade projects; this discourages projects which transcend equipment operational continuity.

### SOLUTION

Dual purpose technology offers a reliable alternative to address these problems. This technology enables gradual upgrade, making it possible to defer a large part of the expenses and shutdown times. By adding the dual purpose (DP) solution to the previous table, we obtain the following:

TASK	UPGRADE TO AC	UPGRADE OF DC DRIVES ONLY	DP UPGRADE
New Transfermer	POSSIBLE	NO	POSSIBLE
New Drive	YES	YES	YESNO
Motor Change	YES	NO	
Others			

The DP solution uses a DC to AC inverter to energize a DC motor. In order to achieve this, only dV/dt filters are added and the remaining modifications are done via software. This solution makes it possible to change the drives first, and change the motors later or gradually.

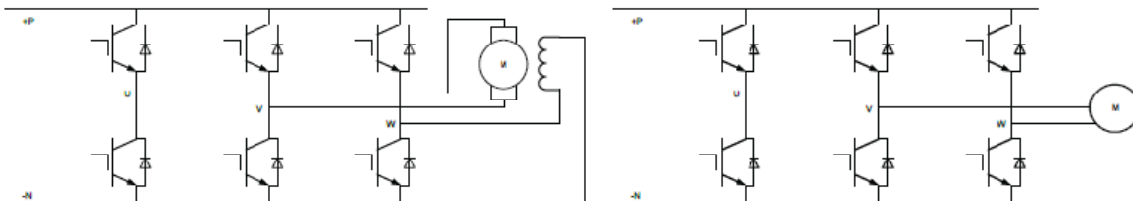

Figure 1.

The following figure presents two graphs showing the costs per year according to the installation type.

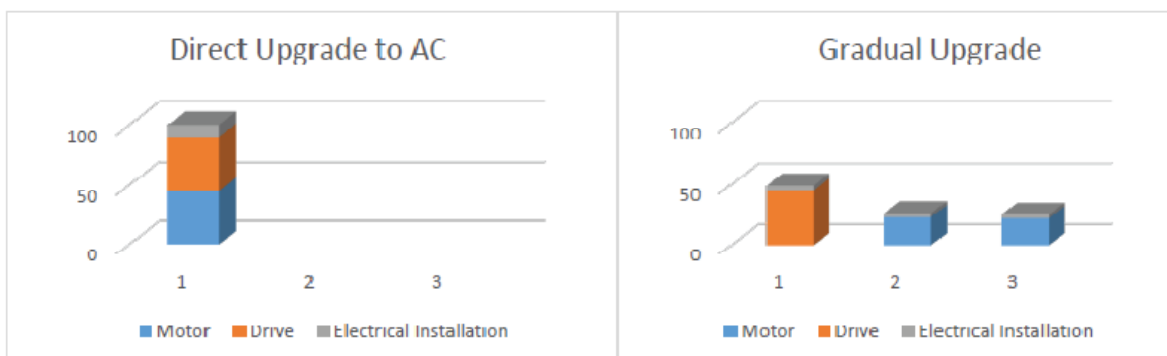

Figure 2. Investment in percentage vs. time.

## SOLUTION ANALYSIS

In order to better analyze the solution, a brief description is presented of the DC drive technologies based on thyristors and AC drive or inverter technologies based on PWM, which represent both sides of the upgrade.

### Thyristor-based DC drives

The rectifiers most commonly used as DC drives are full-wave three-phase rectifiers, similar to those shown in the figure.

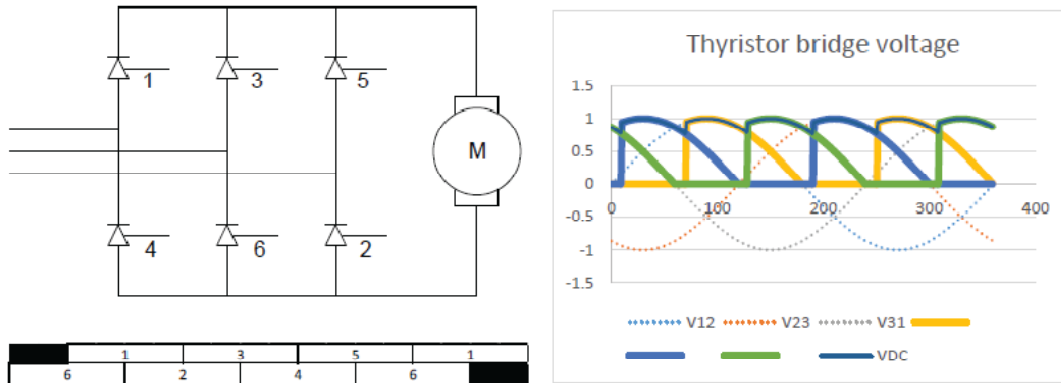

Figure 3. Above left is a thyristor bridge; in the lower left is the order of triggers, and on the right, the waveform.

Thyristors are triggered in pairs, sequentially and in coordination with the power supply, allowing current to flow through the motor armature. If two thyristor bridges are stacked, current can flow both ways. Due to the nature of thyristors -which only switch off when voltage is inverted- and in order to invert current direction, a special sequence takes place which prevents the bridges from being triggered simultaneously, and bridges are swapped only until current disappears in order to avoid commutation faults. This way, the direction of motor rotation can be regenerated or even changed.

### AC drives based on PWM (IGBTs)

Inverters use a bridge H, similar to the one shown in the figure.

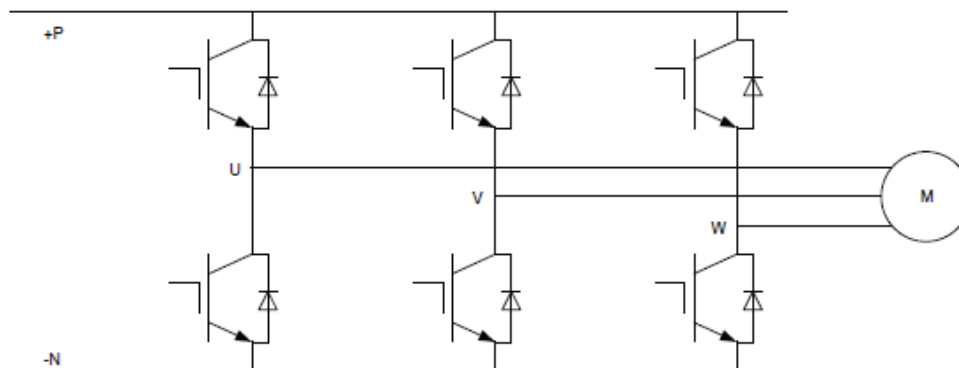

Figure 4. Inverter IGBT Bridge.

These inverters are powered from a fixed voltage DC source. By means of positive and negative pulses, and by modulating pulse width, said inverters are able to generate a voltage wave with an effective voltage equal to a sine wave. These are triggered in pairs, allowing voltage to flow in such a way that they simulate a complete three-phase system.

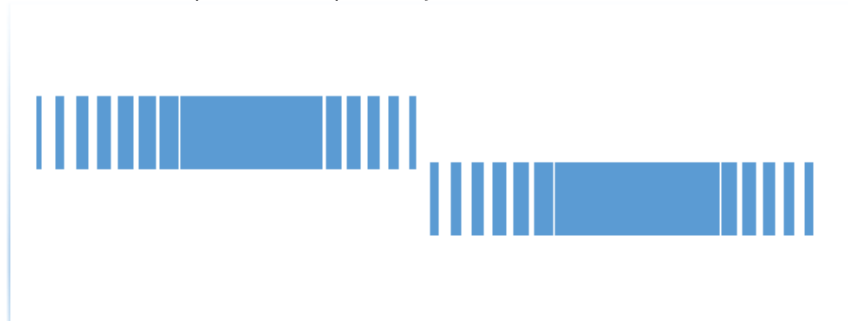

Figure 5. Inverter waveform.

Thyristors are triggered in pairs, sequentially and in coordination with the power supply, allowing current to flow through the motor armature. If two thyristor bridges are stacked, current can flow both ways. Due to the nature of thyristors -which only switch off when voltage is inverted- and in order to invert current direction, a special sequence takes place which prevents the bridges from being triggered simultaneously, and bridges are swapped only until current disappears in order to avoid commutation faults. This way, the direction of motor rotation can be regenerated or even changed.

### Dual Purpose Drive

One of the benefits of an inverter is that it can generate positive or negative voltage. By taking advantage of this, it is possible to generate direct current and move a motor by modulating pulse width. The following figure shows the connection between the DC motor and the IGBT bridge.

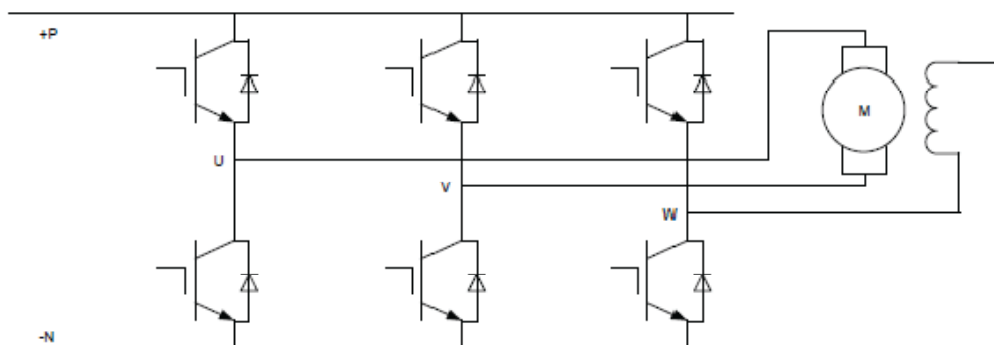

Figure 6. Connection from inverter to DC motor.

Phases U and V are used to connect the armature. For flow in one direction, the U+ and V- IGBTs are used. For flow in the opposite direction, V+ and U- are used. By modulating pulse width, effective voltage is controlled, which results in accurate current control.

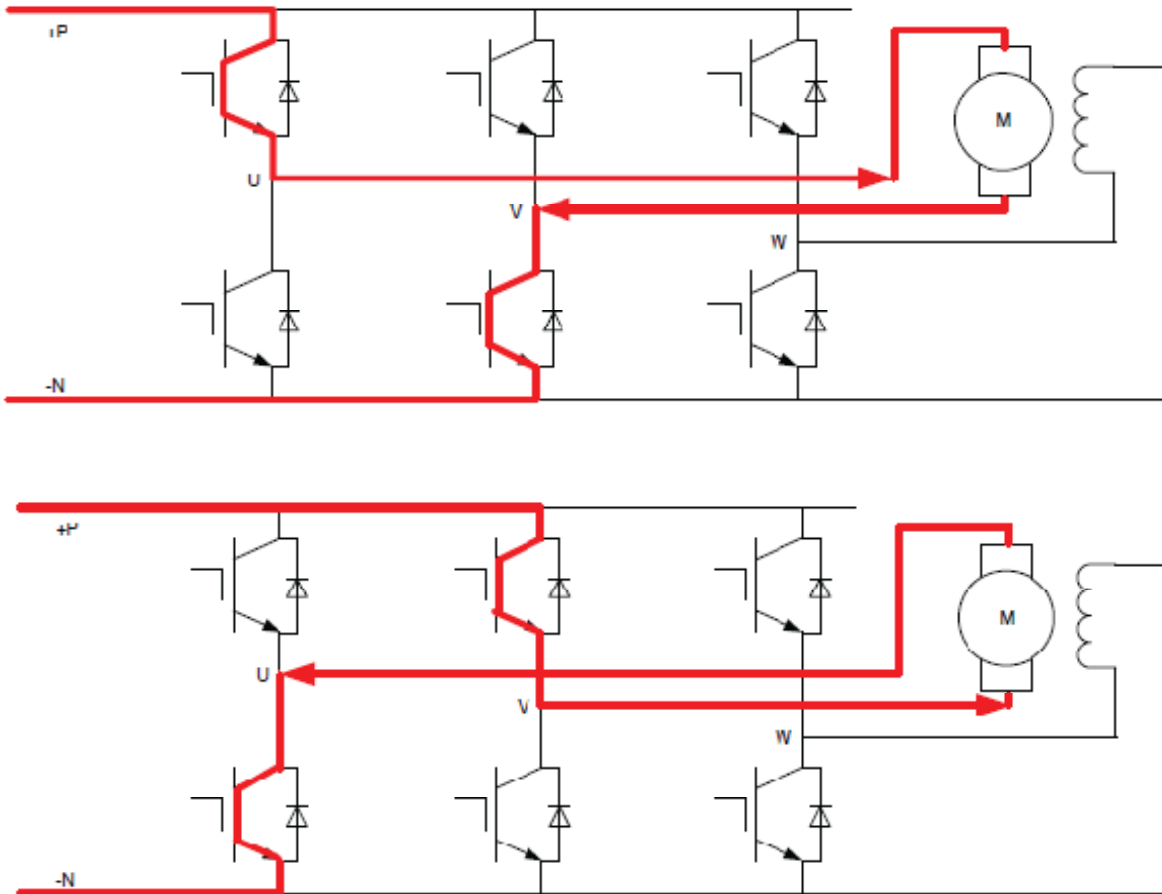

Figure 7.

Since it is an IGBT-based drive, there is no risk of commutation failure when inverting armature current direction, as it is done by a thyristor-based drive.

Phase W is used to connect to the motor field. In this case, the field is connected between phase W and one of the direct current source poles (it may be any one of the two, it can be configured and it depends on hardware). Final connection is as follows:



Figura 8

The biggest challenge for this new solution was that old motors were designed to support the waveform of a thyristor-based drive, and now they are subjected to pulses with high voltage peaks which also have a considerably high  $dV/dt$ . This could lead to insulation deterioration. In order to mitigate this risk, a filter is added between the drive and the armature, and the same with the field. The purpose is to keep voltage peaks low and have a  $dV/dt$  which does not damage the motor. In the case of the armature, two different strategies were implemented with satisfactory results.

### Strategy 1

An RLC filter designed to reduce  $dV/dt$  to less than 250V/us.

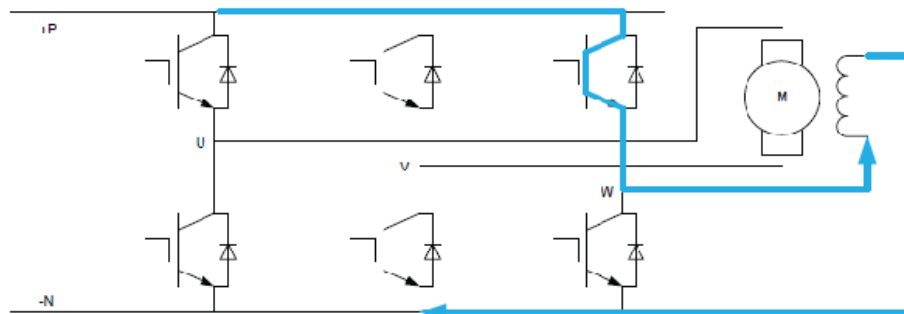
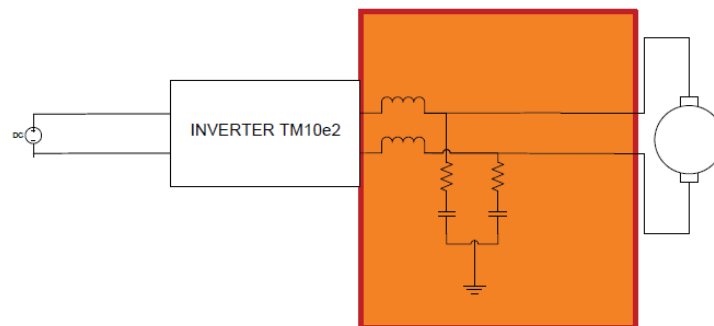

Figure 9.

Wave results in the filter were the following:



Figura 10.

### Strategy 2

An innovative LClip filter with the same purpose as strategy 1.

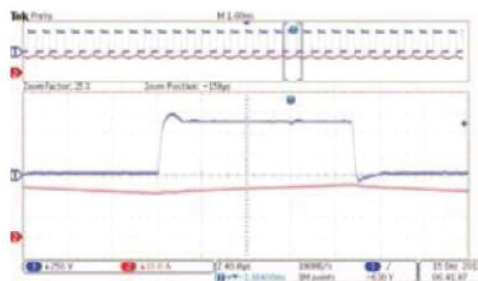

Figure 11.

The LClip filter is limited by the same direct current bus. Wave results in the filter were the following:

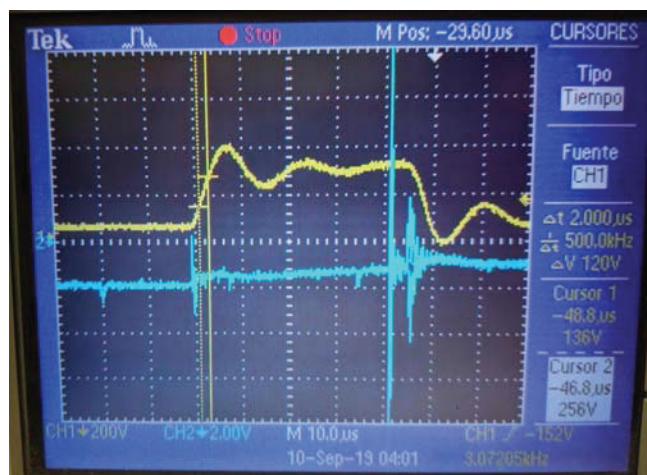

Figure 12.

Below is a list of the benefits of each filter.

RLC	LClip
Easy to understand due to its classic design	More efficiency.
No protection required	Lower inductance.
	Less space.
	Its design depends on drive size, not motor size.

The field filter applies strategy 1, but in addition to that, a crowbar protection is added to avoid equipment over voltage.

### Electrical installation

These drives are powered by direct current, and therefore a direct current supply must be installed, either shared by several inverters or exclusive to one. Depending on application, the direct current voltage source could have the capacity to regenerate or add a regenerative source or a braking unit. It is entirely possible and valid to install inverters in the same direct current voltage bus, regardless of whether they are meant to propel an alternate current motor or a direct current one. It is important to clarify that it is possible to combine both options in the same bus.

The following figure shows a real electric installation at the entrance of a pickling line where AC and DC motors are combined in the same inverter line.

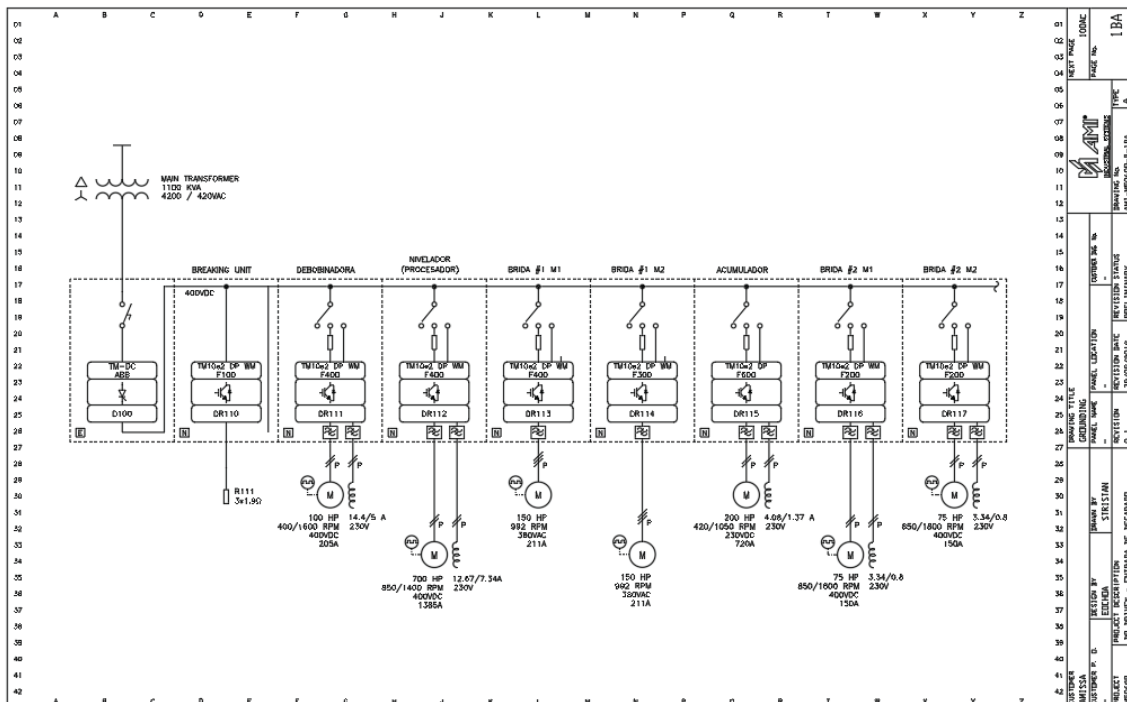

Figure 13.

### Firmware

Firmware development was achieved by combining TM10e2 (inverter) firmware with certain key characteristics of TMDCe2 (firmware for thyristor-based drives). Firmware has all the necessary characteristics of a direct current drive and it has certain special algorithms to prevent motor overvoltage. Moreover, it has numerous tools designed specifically for processes concerning metals such as feed-forward compensation, impact and load balance, among others.

### Change from DC to AC motor

At a future point in time, the user decides to change to an alternate current motor. The user shall follow the procedure below:

1. Decommissioning filters used to run the DC motor.
2. Installing and connecting the AC motor.
3. Installing firmware for AC motor in the equipment.
4. Tuning the motor.

It is of utmost importance to mention that after changing from a DC to an AC motor, the drive will be able to run a 50% more powerful motor than the DC motor.

### Expansion of firmware development

After developing the DP Drive, reversible field sources were created which have been used in long product rolling applications, among others. In this case, phases U and V are used to energize the direct current motor field, and phase W is used as a brake source, to dissipate the energy generated by sudden changes of current decrease, or in other words, plug-in situations. The following figure shows equipment connection:

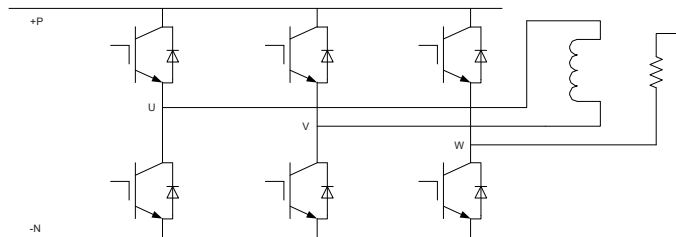

Figure 14.

The following figure shows field inversion for fast stoppage.

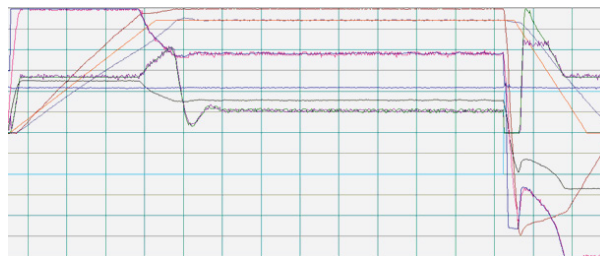

Figure 15.

Growth continues as different applications are still being developed for the steel and other industries.

## **CONCLUSIONS**

This new option emerges as a possibility to upgrade the drive system's electric equipment pursuing the strategic goal of being at the forefront of technology, while monitoring cash flow. This option presents an operative and financial advantage for the final user, since it is possible to schedule shorter shutdown times and defer costs, which facilitates financing. This alternative also enables equipment to become more powerful in the future. In addition to the benefits mentioned above, this solution offers embedded safety capacity; with the right hardware configuration, the equipment could have intrinsic safety level 2.

This option has been tested in different processes in the steel and other industries, where successful results have been achieved fast.

## **REFERENCES**

Stevenson, A. (2003). Power Converter Handbook: Theory, Design, Application. UYK Technologies.  
Sondek, R., Tesendorf, U. (2018). Upgrade Legacy DC Drives to AC Now, and Worry About Motors Later, AISTech2018