

Using High-Tech Dual-Purpose Drives to Upgrade Steel Handling Motion System in Meltshops

Bernardo Sainz¹, Rommel Villarreal², Eric Martinez³

¹AMI Automation
Diaz Ordaz 402, NL, México, 64650
E-mail: bernardo.sainz@amiautomation.com

²AMI Automation
Diaz Ordaz 402, NL, México, 64650
E-mail: rommel.villarreal@amiautomation.com

³AMI Automation
Diaz Ordaz 402, NL, México, 64650
E-mail: eric.martinez@amiautomation.com

ABSTRACT

The material handling in Melshops, responsible for moving molten steel, slag, or scrap, faces reliability issues due to vintage DC motor controls. Moving to AC infrastructure is sometimes prohibited. However, Dual-Purpose Drives offer a cost-effective, reliable solution by reusing the current power infrastructure. Each motion gets a PWM drive for precise control, ensuring speed and torque regulation. The system can also handle mechanical brakes and provide redundancy, ensuring uninterrupted operation. This upgrade also paves the way for future AC motor replacements.

Keywords: PWM, upgrade vintage systems, DP drive, efficient use of energy, reduce wear, material transfer system, DC series field motors, modernization

INTRODUCTION

The material transfer system of the meltshop is one of the critical systems for continuous production. It oversees the transportation of the pot with molten steel, slag, or scrap. Vintage systems use DC series field motors driven by electromechanical contactors and fed from a DC constant potential exciter. These systems lack proper torque control, causing overloads and wear in motors and electromechanical components. Reliability is one of the major concerns due to the high costs of stopping production and added safety issues. Most of the time, vintage systems are supposed to run the same way as they are because most upgraded solutions require expensive modifications to the actual infrastructure.

Recent advancements in Dual-Purpose Drives have cleared the path for automating existing systems. They represent a cost-effective alternative to traditional electromechanical DC contactors previously employed to power the material transfer DC motors because they allow the reuse of the current infrastructure, like the constant potential exciter. With the new system, each wheel on the slag car is managed by its own individual PWM drive for the DC motor, providing speed regulation, torque, current regulation, and load sharing.

Furthermore, this dual-purpose drive can effectively manage the series field in the DC motor and brake circuits typically used in this application. An added advantage of this system is its redundancy feature; in the event of a drive failure, another drive can seamlessly take over, maintaining uninterrupted operation. This upgrade methodology also prepares the system for a future AC motor replacement if possible.”

DISCUSSION

Problem description

The vintage cranes and material transfer systems are driven most of the time by series fields DC motors. These motors are controlled by electromechanical contactors and resistors, and the system is fed by a DC constant potential exciter (usually 250VDC). All the infrastructure is prepared to run with a DC voltage power feeder.

The next image shows a typical and simplified electrical diagram of the vintage motor control of most of the existing system described in this paper.

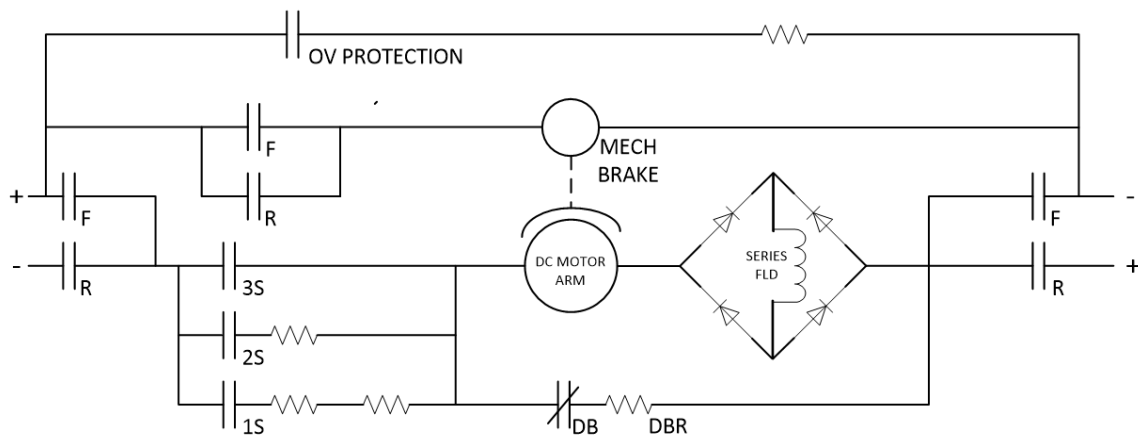

Figure 1.

The series field of the motor is routed through a diode circuit to ensure that the flux remains consistently oriented. Motor activation is achieved by closing either the F (Forward direction) or R (Reverse direction) contactors. In this specific configuration, three distinct speeds are available, selected by the 1S, 2S, and 3S contactors. Notably, the 1S contactor incorporates two resistors in series, functioning as voltage dividers with the motor, thereby limiting the voltage supplied to the motor and reducing its speed. Similarly, the 2S contactor reduces motor voltage, though to a lesser extent compared to 1S, allowing for a higher speed. The 3S contactor delivers full voltage to the motor.

If the load drives the motor, causing it to behave as a generator (regeneration), the voltage in the bus will naturally begin to rise. To prevent overvoltage, a protection mechanism within the power source activates, diverting excess energy through a resistor. When the motor is commanded to stop, the F or R contacts open, and the dynamic brake (DB) engages to decelerate the motor. Additionally, each time motor movement is initiated, the mechanical brake coil (MECH BRAKE) energizes to release the brake, automatically closing when the forward or reverse command is released.

Despite the functionality of these vintage systems, several weaknesses exist that may impact equipment reliability both in the short and long term. These include wear on the commutator and contactors, lack of control accuracy, and insufficient diagnostic capabilities. While maintenance personnel in the meltshop acknowledge these inherent challenges, they also recognize them as opportunities for improvement.

Wear on the commutator and contactors occurs each time the motor is activated, as different contactors close to allow a predetermined voltage to pass through resistors controlling speed. This process can lead to an aggressive increase in current, limited by the resistance and inductance of the series field and armature circuit, potentially causing accelerated wear on the motor's commutator. Furthermore, the repetitive opening and closing of contactors under load can result in micro-arcing, contributing to contact wear. The use of resistors to reduce voltage also represents an inefficient energy dissipation method.

The lack of control accuracy associated with motor operation via contactors introduces reliability issues and impacts equipment longevity. Improved control accuracy not only enhances equipment reliability but also facilitates operational predictability for operators.

Finally, the challenge of gathering diagnostic information arises due to the inherent nature of the process, where motor currents are not typically measured. Consequently, motor or drive system failures may only become evident following a breaker trip or other noticeable malfunction, complicating maintenance diagnostics and potentially prolonging downtime. The cessation of auxiliary systems due to a failure can halt production throughout the entire plant.

Analysis and solution proposed

Three issues have been identified: mitigating wear on motor commutators and contactors, enhancing control accuracy, and facilitating diagnostic data collection or control enhancement. While the installation of a drive may seem like a straightforward solution, several challenges must be addressed. Primarily, most DC drives available on the market are designed for use with alternating current and are tailored for separately excited DC motors, rather than series motors commonly found in these applications. Alternatively, another avenue involves the implementation of a chopper configuration power electronic system; however, this option introduces its own set of intricacies. Specifically, issues arise such as the degradation of motor insulation attributable to the high dV/dt and overvoltage, as well as challenges related to the capacitor bank when the power supply typically comprises a 250VDC constant potential exciter (CPE) regulated by thyristors, diodes, and a saturable reactor, lacking mechanisms for ripple reduction.

To meet the requirements of DC-fed systems, the optimal solution lies in the implementation of a Dual-Purpose Drive. This specialized drive employs a chopper configuration utilizing Pulse Width Modulation (PWM) to adjust the DC voltage supplied to the motor. A simplified diagram illustrating this configuration is depicted in the following image.

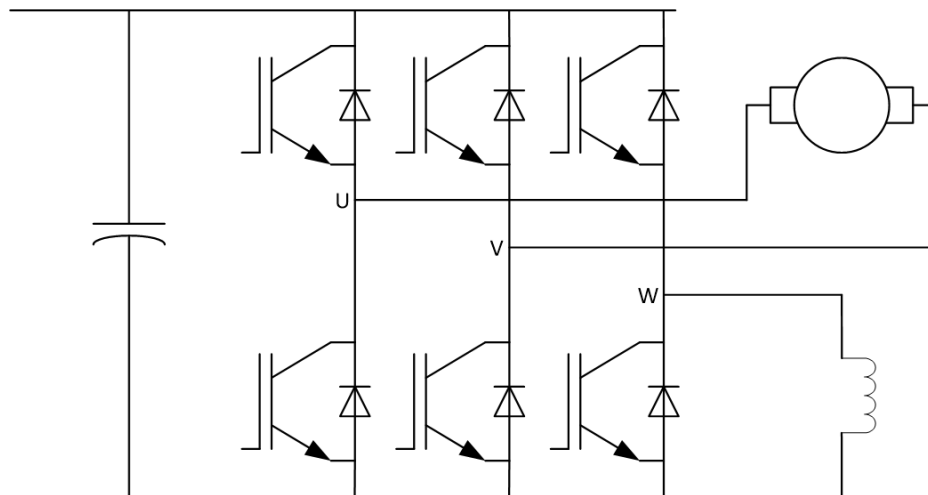

Figure 2.

The Dual-Purpose (DP) drive utilizes an inverter configuration to operate a DC motor effectively. In this configuration, typically, phase U and V are employed to supply power to the armature of the motor, while phase W and the negative pole are utilized for the field (although it is also possible to run the field between W and the positive pole).

To achieve forward motion, the IGBTs (Insulated Gate Bipolar Transistors) corresponding to +U and -V are gated, whereas for reverse motion, +V and -U are gated accordingly.

The DP drive is powered by a constant potential exciter, which typically serves multiple applications and is often oversized, energizing numerous motors and contactors simultaneously. Due to the low transformer reactance and the potential for Voltage Ripple, which may damage the capacitors of the DP drive, precautions must be taken. To mitigate this risk, a diode is incorporated into the DC incoming power supply, as depicted in Figure (3). Additionally, the drive necessitates a disconnection device from the DC bus and a pre-charge system to energize the capacitor bank safely.

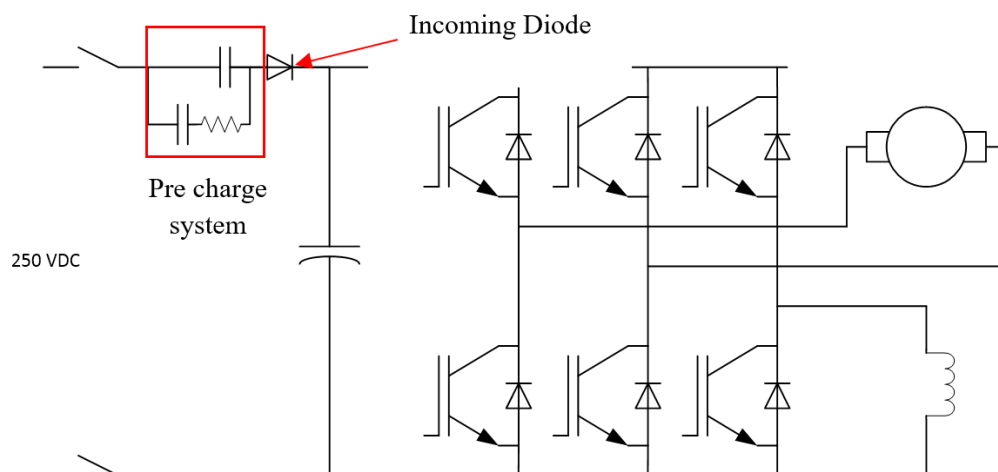

Figure 3.

Running the motor through a drive brings better torque and speed control. Two different schemes are proposed for running a series motor.

A.- Run the motor as series motor:

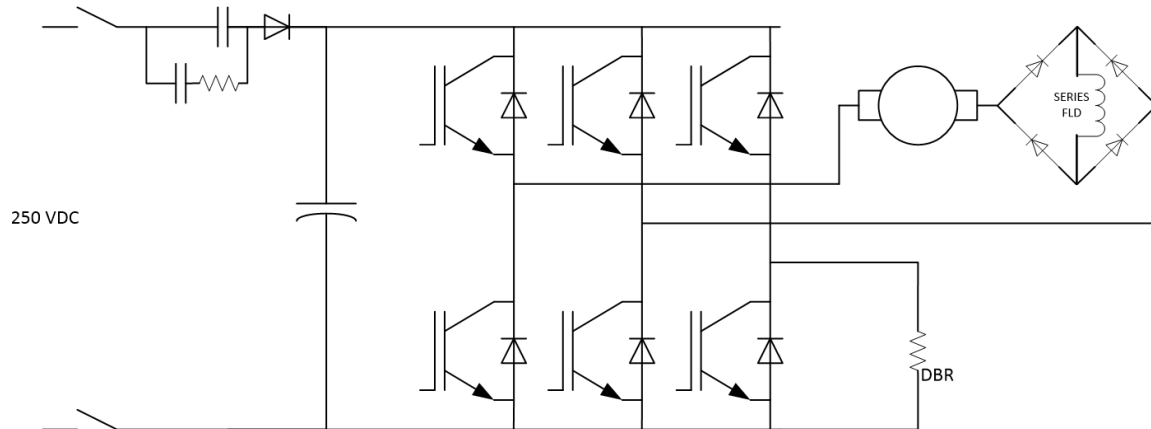

Figure 4.

Implementing this scheme offers several advantages, yet it also presents areas for improvement. In this setup, the series motor field remains connected in series through diodes that dictate the direction of the field current. Notably, the field circuit between W and the negative pole can serve as a dynamic brake transistor, with the DBR (Dynamic Brake Resistor) connected within this circuit (the drive gives the possibility of using the W phase as braking transistor. When the motor requires deceleration, the energy of the motor is dissipated in a controlled manner through the DBR. This feature proves invaluable when the control system endeavors to slow down the motor and encounters regenerative energy, as the energy can be effectively dissipated in the resistor.

However, a notable disadvantage of this scheme lies in the challenge of predicting the motor's speed and torque due to fluctuations in flux with varying loads. Specifically, when a specific voltage is applied, an increase in load leads to a corresponding increase in armature current, generating torque. Simultaneously, the flux increases proportionally. Since motor speed is inversely proportional to flux, the speed of the motor decreases under load. Conversely, a decrease in load results in a reduction in armature current and flux, potentially causing a dramatic increase in speed. This inherent variability makes it challenging to control speed and torque accurately. Nevertheless, the scheme does offer the ability to control voltage and produce a controlled current rate of rise, which aids in reducing wear on contactors and motor commutators.

B.- Run the motor as separately excited motor.

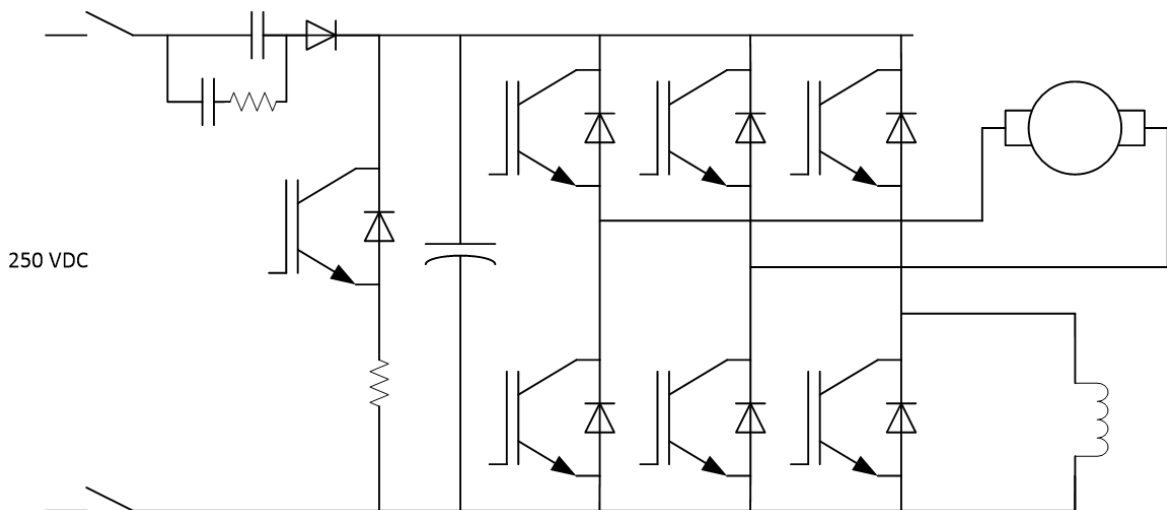

Figure (5-a).

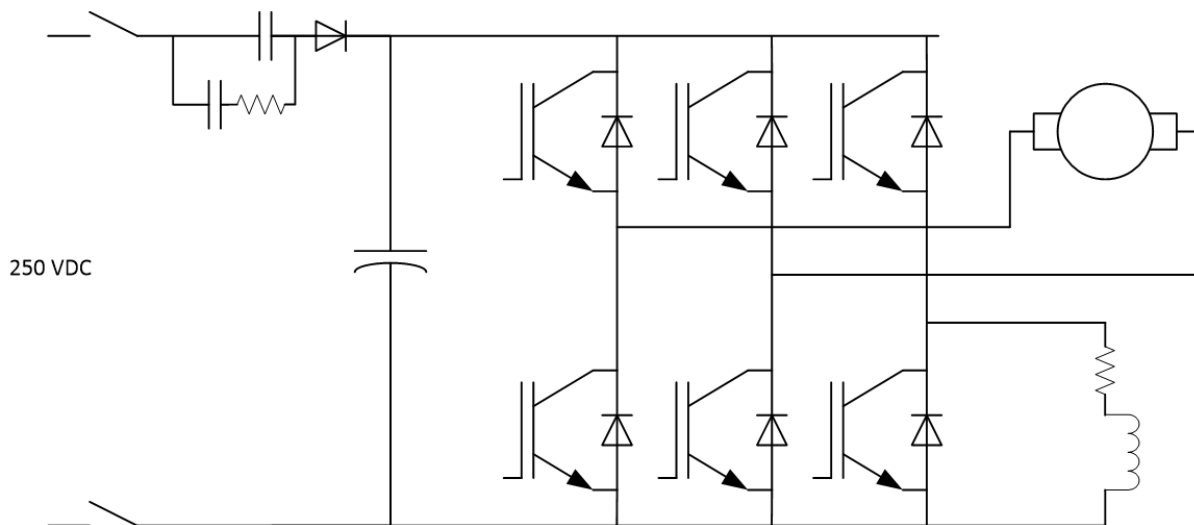

Figure (5-b).

In this setup, the series field will be independently excited using the DP drive's W phase. Scheme B presents several advantages. When the motor field is fixed, predicting the torque of the machine becomes easier, thereby enabling better speed regulation. There are two options available:

Option 1 (Figure 5-a) The dynamic brake resistor is connected to an external braking transistor. This option offers the advantage of higher efficiency since the Dynamic Brake Resistor (DBR) is not continuously activated.

Option 2 (Figure 5-b) involves connecting the DBR resistor in series with the field, providing benefits such as:

- Increased voltage, which assists Pulse Width Modulation (PWM) in better regulation of the field current
- A resistive load is always available for motor energy dissipation during regeneration.

However, a drawback of Option 2 is that energy is continually dissipated in the dynamic brake resistor while the motor is running, decreasing system efficiency. Nonetheless, since the system operates intermittently (e.g., cranes or ladle cars running only for short periods), this disadvantage is mitigated.

In cases where the DBR cannot handle the entire field current for a specific duration, a hybrid mode can be developed. In this mode, one part of the current remains fixed while another part varies directly proportional to the armature current. Although this configuration mimics the behavior of a compound motor and complicates torque calculation for the drive, it does not adversely affect voltage regulation at the motor terminals.

The next table compares the two new schemes and the vintage one.

	Vintage configuration	Scheme A	Scheme B
Wear	High wear is experienced due to the instantaneous high load on the contactors and motor commutator, compounded by a potentially rapid increase in current.	Wear is mitigated through controlled current management of the motor using the drive, eliminating the need for electromechanical contactors for motor initiation, thereby reducing wear.	Wear is mitigated through controlled current management of the motor using the drive, eliminating the need for electromechanical contactors for motor initiation, thereby reducing wear.
Torque and speed control	Current control is not implemented; instead, the motors are operated with a fixed voltage and regulated using resistors.	Voltage control is highly precise but lacks torque regulation due to the parallelism of field and armature currents. <ul style="list-style-type: none"> Controlled rate of current rise is maintained. 	<ul style="list-style-type: none"> Accurate voltage control is ensured. Operation without load is feasible due to the presence of a fixed field component. Enhanced torque control is achieved owing to the fixed field component. Controlled rate of current rise is maintained.
Diagnostics and protections	Generating diagnostics with this configuration is typically challenging due to limited instrumentation available for such systems.	This configuration offers high-speed trending, an event log, and instantaneous trip capabilities facilitated by power electronics.	This configuration offers high-speed trending, an event log, and instantaneous trip capabilities facilitated by power electronics.
Efficiency	Low efficiency caused using resistors to decrease the voltage of the motor, to control the speed.	High efficiency system	<ul style="list-style-type: none"> High efficiency if DBR is used with an over voltage protection unit. Medium Efficiency if DBR is connected in series with field circuit.

In every solution, the motor is protected versus dV/dt and over voltages caused by the PWM gating by high efficiency LC filter in the armature and field circuit.

RESULTS

Implementation and overall performance

The solution, Scheme B, was implemented for the slag car of a Basic Oxygen Furnace (BOF). The system operates with two series motors that facilitate movement. Originally, the system was powered by a 250VDC constant potential exciter, employing contactors and resistors to regulate motor speed and direction.

The proposed system, resembling Scheme B, introduced two drives. To enhance field control and optimize chopper efficiency by delivering increased voltage, both motor fields were connected in series and controlled by a single drive. In the original setup, motor current passed through the brake coil. However, in this new scheme, the field brake coil is integrated into the field circuit. Consequently, the field current flows through the motor until a run command is received by the drive, initiating motor operation. Armatures are controlled independently by each drive. However, in the event of a drive failure, both drives possess the capability to run both motors in parallel. This option is facilitated by contactors designed to open and close without load. If the drive controlling the fields malfunctions, field control is seamlessly transferred to the second drive.

Figure (6) depicts a single-line diagram of the system, illustrating the integration of these components.

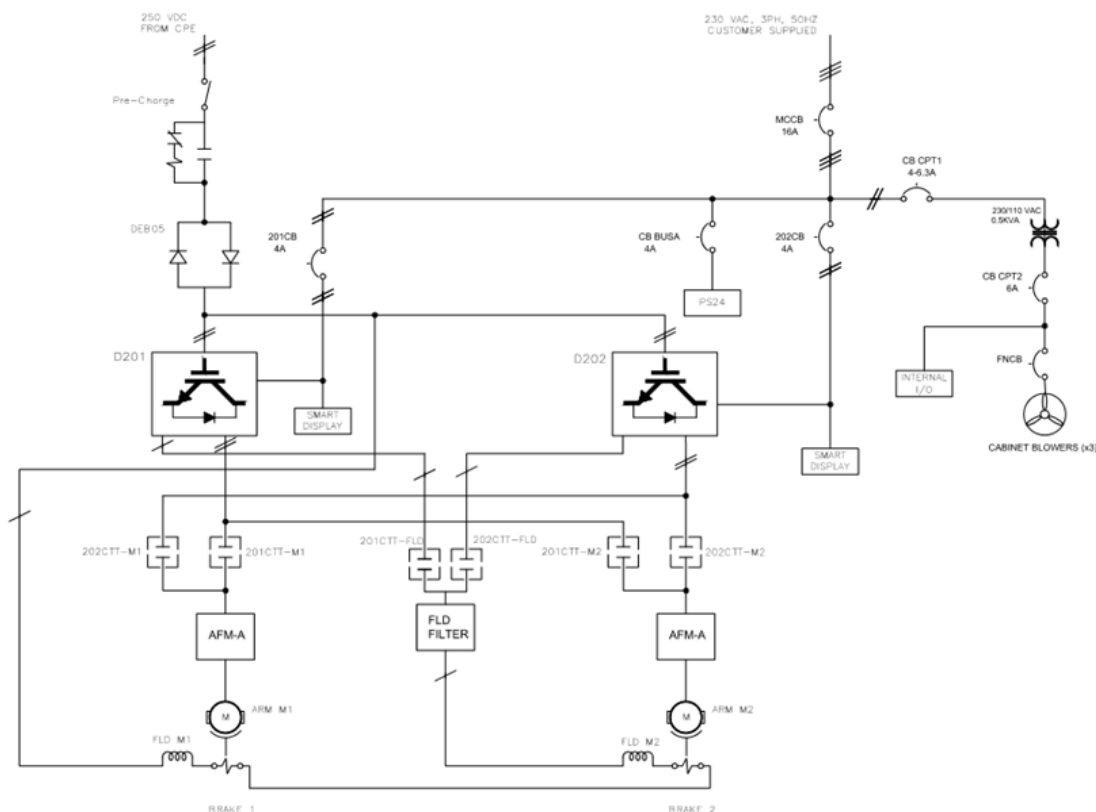

Figure 6.

The next trend is a general shows the slag car working.

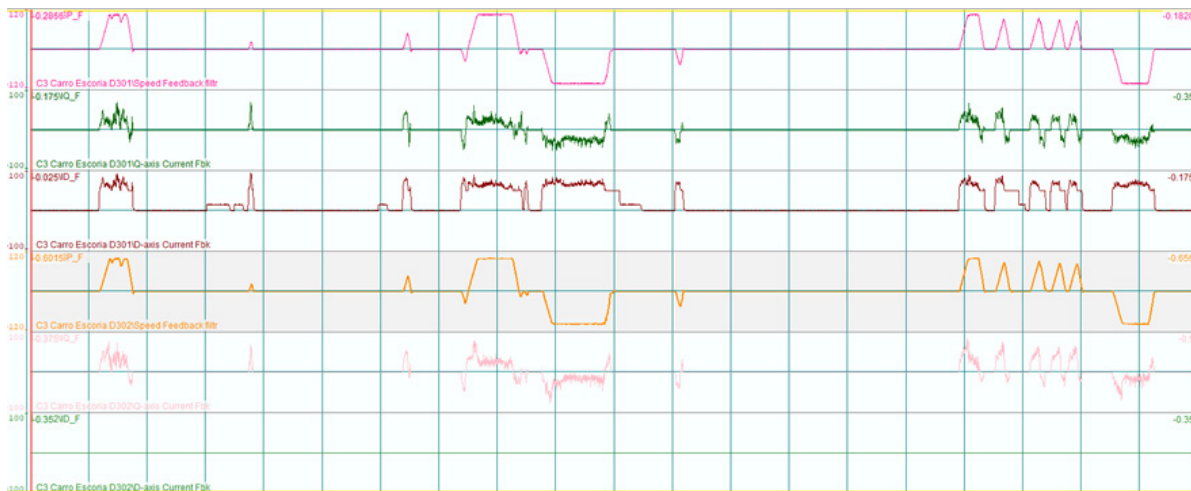

Figure 7.

For this kind of scheme, the field current is fixed and is increased proportionally to the load. The field current reference is given by the next equation.

$$\text{Field Current} = \text{Fixed Field Reference} + I_{arm} G$$

In the following figure, the brown line represents the field current. In this scenario, the fixed field constitutes 50% of the total current, while the remaining field current derives from the armature current multiplied by a predetermined gain. The initiation of field current flow occurs when motor movement is desired, concurrently activating the loss of field protection mechanism.

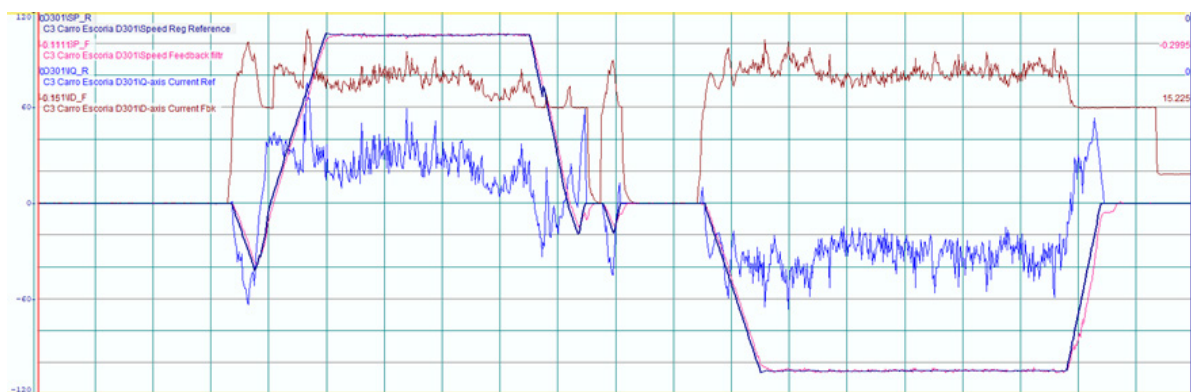

Figure 8.

The load balancing between two drives is accomplished utilizing a droop technique, wherein the speed reference is modulated by a proportional gain corresponding to the motor load. Through this method, as the load on the motor increases, the speed reduction proportionally increases, facilitating the natural equilibrium of the motor to attain a comparable load distribution. The following figure depicts the droop gain and speed reference for each drive, offering visual insight into the implemented technique.



Figure (9-a).

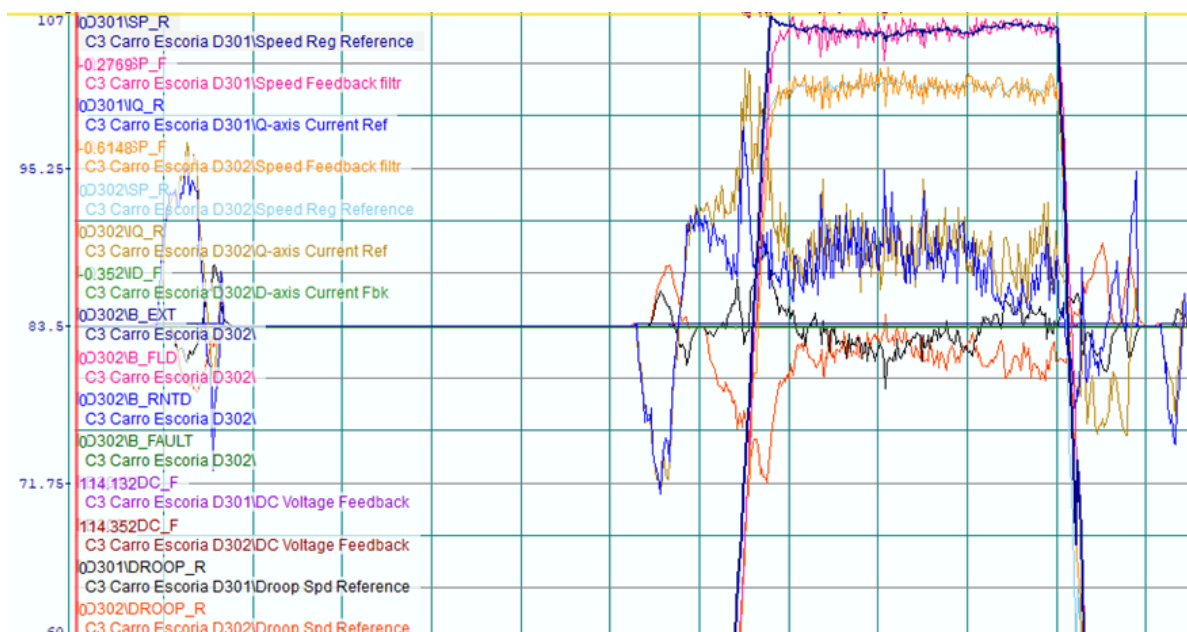

Figure (9-b).

Following the erection of the system, production commenced with minimal subsequent adjustments. The outcomes yielded several notable benefits:

- Substantial reductions in maintenance expenditures and downtime attributable to the cessation of contactor usage.
- Implementation of a current-controlled, rate-of-rise DP drive is anticipated to prolong the operational lifespan of the motors.
- Integration of novel maintenance and diagnostic tools presents opportunities for streamlined troubleshooting and the acquisition of valuable operational data.
- Utilization of the pre-existing 250VDC CPE not only minimized equipment installation costs but also avoided the need for infrastructure modifications.

CONCLUSIONS

Utilizing the DP drive to modernize vintage systems has emerged as a reliable solution, presenting novel control capabilities. For instance, when integrated into crane systems within a facility, it facilitates the implementation of sophisticated positioning controls, simplifying the regulation of the hoist position—a task considerably more challenging with vintage systems reliant on basic on-off controls.

Moreover, this state-of-the-art digital technology encompasses diagnostic tools crucial for fault analysis and gathers operational data essential for monitoring purposes. By employing controlled rate of rise mechanisms to manage motor currents, wear issues concerning motor commutators are significantly mitigated. Additionally, the elimination of contactors addresses wear-related concerns, leading to a reduction in maintenance needs and associated costs. Notably, the incorporation of an LC circuit safeguards the motor commutator, preventing overvoltage scenarios and maintaining dV/dt within specified parameters.

Furthermore, there's a notable improvement in energy efficiency. Unlike vintage systems that dissipate energy as heat through resistive voltage division, the DP drive utilizes pulse width modulation to regulate motor voltage, achieving an efficiency rate of approximately 98%. This represents a significant enhancement over scenarios where motors operate consistently below full voltage, dissipating energy as heat through resistor-based voltage division.

BIBLIOGRAPHY

1. DP Drive Documentation
2. AMI engineering documentation
3. Siskind, Electrical Control Systems in Industry