

# Upgrading SVC Firing Circuitry at JSW Steel Ohio Boosts EAF Performance

*Eric Martinez Mora<sup>1</sup>, Juan Masso Mejorado<sup>2</sup>, Bernardo Sainz Barajas<sup>3</sup>, Jose Luis Pepe<sup>4</sup>*

<sup>1</sup>AMI Automation  
Diaz Ordaz 402, NL, México, 64650  
E-mail: alejandro.guerra@amiautomation.com

<sup>2</sup>JSW Steel  
1500 Commercial Avenue, Mingo Junction, OH 43938  
E-mail: juan.mass@jswsteel.us

<sup>3</sup>AMI Automation  
Diaz Ordaz 402, NL, México, 64650  
E-mail: bernardo.sainz@amiautomation.com

<sup>4</sup>AMI Automation  
Diaz Ordaz 402, NL, Mexico, 64650  
E-mail: jose.pepe@amiautomation.com

## ABSTRACT

Static VAR compensators (SVC) in large Electric Arc Furnaces, especially those above the 100MW range, predominantly employ TCR technology which has been in use for over 30 years. While thyristor valves remain durable, control systems face obsolescence and integration challenges with new technologies. Instead of replacing the entire system, an upgrade solution from AMI Automation was implemented at JSW Steel in Mingo, OH, rejuvenating the control system. The latest AMI PXC platform was introduced, providing enhanced diagnostics and better digital furnace regulator integration. This upgrade revitalized operations, optimizing consumable use and boosting furnace efficiency.

**Keywords:** SVC, FCR, TCR, EAF, Thyristor, Meltshop, Electrode

## INTRODUCTION

### **1. Background**

Electric Arc Furnaces (EAFs) significantly impact power distribution systems, exhibiting inductive behavior with low power factors and producing high levels of harmonics. The intermittent and abrupt load variations of AC furnaces can cause large current unbalances, making the management of power quality a critical aspect of steelmaking processes. The worst-case scenario is intermittent operation in two phases. These characteristics underscore the necessity of a fast-acting, high-efficiency, and highly reliable Static Var Compensator (SVC) system to meet power quality standards and ensure optimal steelmaking processes.

Static Var Compensators play a vital role in addressing these challenges by maintaining near-unity power factors, balancing loads, and minimizing voltage disturbances such as flicker. Equipped with harmonics filters, SVCs effectively mitigate harmonic distortions by targeting specific frequencies generated by EAFs. This not only ensures stable and efficient operation of the electrical system where EAFs are present, improving their power quality variables, but also increases the productivity of the furnace by allowing it to operate at more optimal points.

For large Electric Arc Furnaces above the 100MW range, SVC systems have traditionally relied on TCR (Thyristor Controlled Reactor) technology, combined with shunt-connected capacitor banks, which has proven to be robust and reliable technology over more than three decades. However, the control systems of these older SVCs are facing challenges such as obsolescence and lack of digitalization, prompting the need for upgrades to ensure continued operational efficiency and manage the complex power quality issues associated with high-capacity EAFs.

### **2. Study Objectives and Significance**

The primary objective of this study is to evaluate the impact of the upgraded SVC control system on the productivity of EAFs at JSW Steel, Mingo, Ohio. Specifically, the study aims to:

- Assess the improvement in power quality parameters, including power factor, voltage stability, and harmonic reduction, following the SVC upgrade.
- Analyze the effect of enhanced power quality on the operational efficiency of EAFs, focusing on key performance indicators such as power-on time, electrode consumption, refractory lifetime, and production cycles.
- Investigate the correlation between improved power quality and increased furnace productivity, identifying optimal operating points for EAFs.
- Explore the potential for replicating the SVC upgrade approach in other steelmaking facilities to enhance overall industry productivity.

The significance of this study lies in its potential to demonstrate how targeted upgrades to electrical control systems can lead to substantial improvements in industrial processes. This study highlights the value of upgrading existing SVC systems by investing only in the control system and leveraging the existing power components and infrastructure to meet modern operational and digitalization requirements. A completely new installation can be considered when the existing installation is not available.

By showcasing the benefits of the SVC upgrade at JSW Steel, this research could provide valuable insights for other steel producers seeking to optimize their operations and improve competitiveness in the global market. Furthermore, the findings could contribute to a broader understanding of power quality management in heavy industries, with implications for energy efficiency, operational reliability, and environmental sustainability.

### ***3. SVC Upgrade at JSW Steel, Mingo, OH***

In October 2021, JSW Steel in Mingo, Ohio, USA, awarded AMI Automation for a significant upgrade to the control system of its 250 MVAR 34.5 KV SVC system to enhance the power quality and operational efficiency of its electric arc furnaces. The facility had been operating with a control system installed in 2004 by another manufacturer, which faced challenges such as limited spare parts availability and lack of modern diagnostic and monitoring capabilities.

The upgrade included replacing the control system with the PXC platform from AMI Automation, which provided advanced diagnostics and high-performance control and the Firing Circuit Replacement (FCR) for the Light-Triggered Thyristor (LTT) activation. The primary objectives of this upgrade were to improve SVC availability and to compensate more effectively for reactive power (VARs), thereby enhancing power supply utilization, increasing the power factor, and improving other power quality parameters such as flicker and harmonics. The SVC plays a crucial role in compensating for voltage variations produced by the facility's 140MW AC EAF and 20 MW Ladle Furnace.

The new control system was commissioned and put into operation in April 2022. The upgraded system provides enhanced diagnostic capabilities and better integration with the existing electrical infrastructure, resulting in more stable and efficient furnace operations. This has contributed to the overall productivity and competitiveness of the JSW Steel facility in Ohio.

## **ELECTRICAL SYSTEM**

### ***4. Electrical System Topology***

The electrical system at JSW Steel's facility in Mingo, Ohio, is designed to ensure a reliable and efficient power supply to its high-demand electric arc furnaces (EAFs) and ladle furnace (LF). The topology of the system is characterized by its dual supply lines from the power utility, each rated at 138 kV. This setup provides the flexibility to utilize one or both 220/225 MVA transformers, which step down the voltage to a 34.5 kV bus. From this bus, power is distributed to various loads, including the EAF and LF circuits.

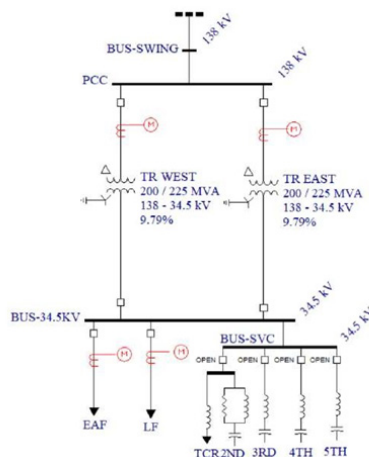

**Figure 1.** Electrical System Simplified one-line diagram.

#### 4.1 Grid

The facility is connected to the power utility grid through two supply lines, each rated at 138 kV. The short-circuit capacity of the power supply at the point of common coupling (PCC) is a critical parameter for the design and operation of the electrical system. The short-circuit parameters are as follows:

Short-circuit parameters	
Supply voltage [kV]	138
Short-circuit power 3f [MVA]	5 549.3
Short-circuit current 3f [kA]	22.547

**Table I.** 138 kV PCC short-circuit parameters

These parameters indicate the robustness of the power supply system and its capability to handle the demands of the steelmaking facility, ensuring uninterrupted operation and optimal performance of the SVC system.

#### 4.2 Incoming Transformer

Power from the grid is stepped down using one or both 220/225 MVA transformers, which reduce the voltage from 138 kV to 34.5 kV. This transformation is crucial for matching the supply voltage to the requirements of the downstream components and loads.

#### 4.3 SVC – TCR & Harmonics Filters

The SVC at the facility is equipped with a TCR and harmonic filters, connected in shunt at the 34.5 kV level. It compensates for reactive power, stabilizes voltage, and mitigates harmonic distortions caused by the EAF and LF.

The TCR employs LTTs AC valves and reactors designed for dynamic reactive power management of each phase. By modifying the LTT valves' firing angle individually, the TCR adjusts the reactive power output, ensuring precise compensation control.

The system includes harmonic filters for the 2nd, 3rd, 4th, and 5th harmonics, each consisting of a bank of capacitors in series with a small inductance to tune filtering frequency and limit transient overvoltage. These filters target specific harmonic frequencies generated by the EAFs, effectively managing power quality issues, and contributing to stable and efficient operations.

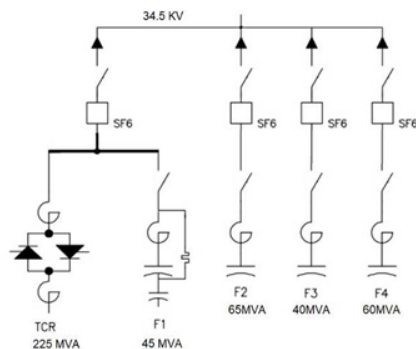

**Figure 2.** SVC One line diagram

- F1 2nd Harmonic: Targets the second harmonic, which can be generated by the operating characteristics of the electric arc between electrodes in arc furnaces and ladle furnaces.
- F2 3rd Harmonic: Mitigates the third harmonic, addressing zero-sequence “triplen” harmonics and system balance.
- F3 4th Harmonic: Addresses the fourth harmonic to improve power quality and protect sensitive equipment.
- F4 5th Harmonic: Reduces the fifth harmonic, which is generated mainly by the TCR in the SVC, leading to voltage distortion and equipment overheating.

Following the upgrade, the control of the SVC at the JSW Steel facility is managed by the AMI DigiSVC control system. This system is specially designed for EAF applications, utilizing advanced algorithms to ensure fast and effective response to load variations. The DigiSVC system features a PCI express chassis for modularity and maintainability, along with a Quad Core processor and high-performance FPGA for executing control algorithms. These algorithms include an open-loop regulator for compensating load variation per phase, and a closed-loop regulator for voltage, power factor, or VAR regulation. Additional functions such as current limit and spillover voltage protection are also integrated into the system. The embedded high-speed measurements eliminate the need for external data loggers, and the arithmetic sum of TCR, loads, and filter currents allows for totalizer current estimation without input CTs, enhancing maintainability. Moreover, the system supports substation transformer primary side power factor regulation with transformer reactance compensation as a function of tap position.

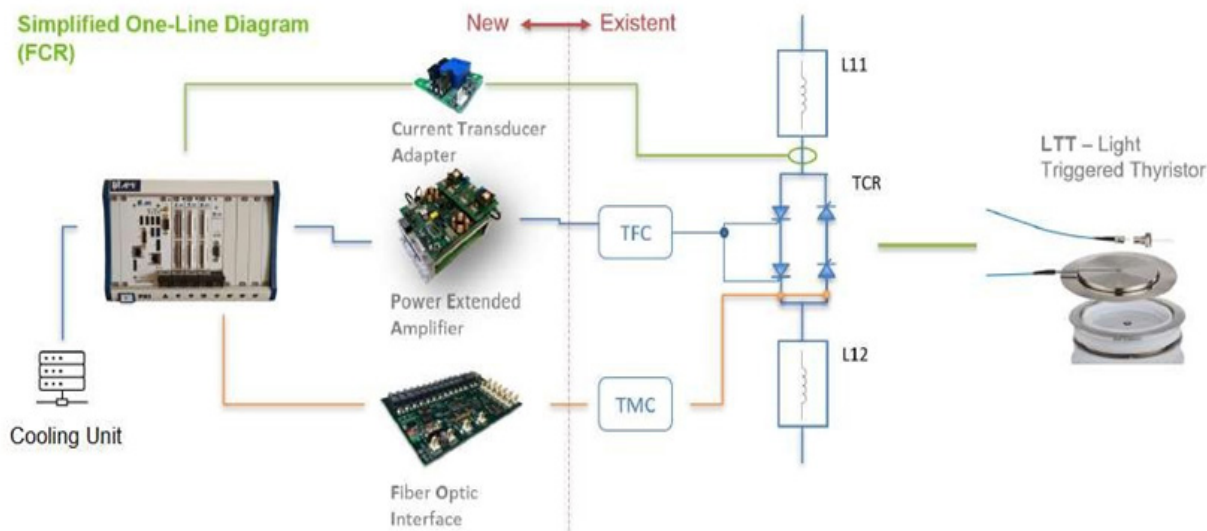

**Figure 3. DigiSVC FCR Control System Topology**

## 5. EAF Transformer and Reactor Tap Changer

The 140/157 MVA 34.5/0.960 kV EAF transformer plays a crucial role in supplying power for the Electric Arc Furnace operations at the facility. Capable of handling high levels of power under severe operational conditions, this transformer not only defines the maximum power available to the furnace but also ensures the delivery of proper level voltage, crucial for maintaining efficiency and steel production quality.

Incorporated into the system, a series reactor with tap changer mechanism allows for fine-tuning of the voltage and current supplied to the furnace. By adjusting the tap position, the power profile of the furnace can be modified, adapting it to the specific needs of each material load and optimizing the melting process. This adjustability is essential for responding to dynamic load variations and maintaining operational stability, minimizing disruptions, and enhancing energy efficiency.

The EAF voltage control system is vital for achieving these objectives. It provides the necessary flexibility to adapt to the changing demands of the furnace operation, ensuring that the power supply is both reliable and adjustable to real-time operational conditions.

The reactance of the transformer and reactor significantly impacts the power factor and flicker filtering. The transformer's reactance leads to the generation of lagging or inductive reactive power. Operating at a higher tap result in reduced voltage with increased inductance, which enhances flicker filtering by providing greater inductive reactance. However, this can affect the power factor at the furnace due to the increased inductive reactance. The SVC system can achieve voltage stability and flicker control, allowing the furnace to operate at a higher tap, thereby improving the power factor at the furnace electrodes and ensuring a more consistent and quality power supply to the furnace.

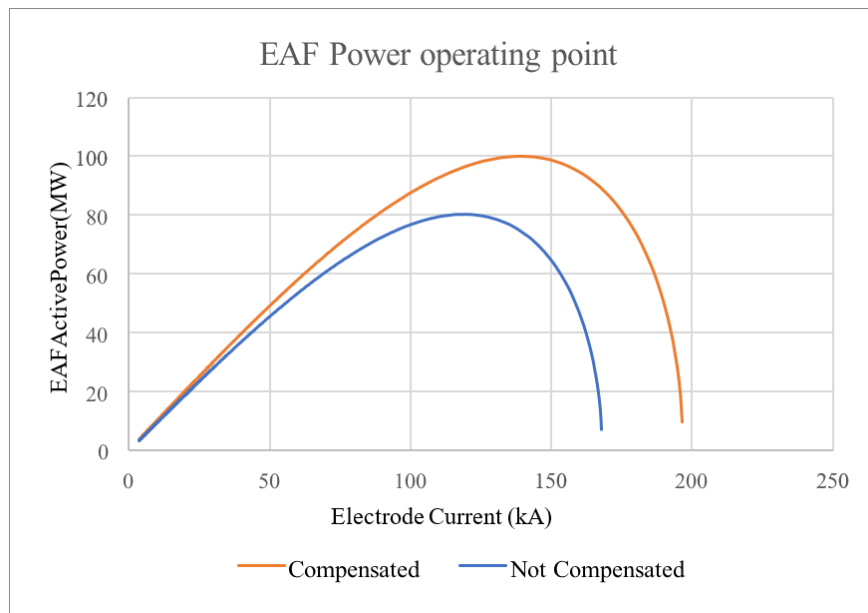

**Figure 4. EAF operating point with/ without SVC Active Power**

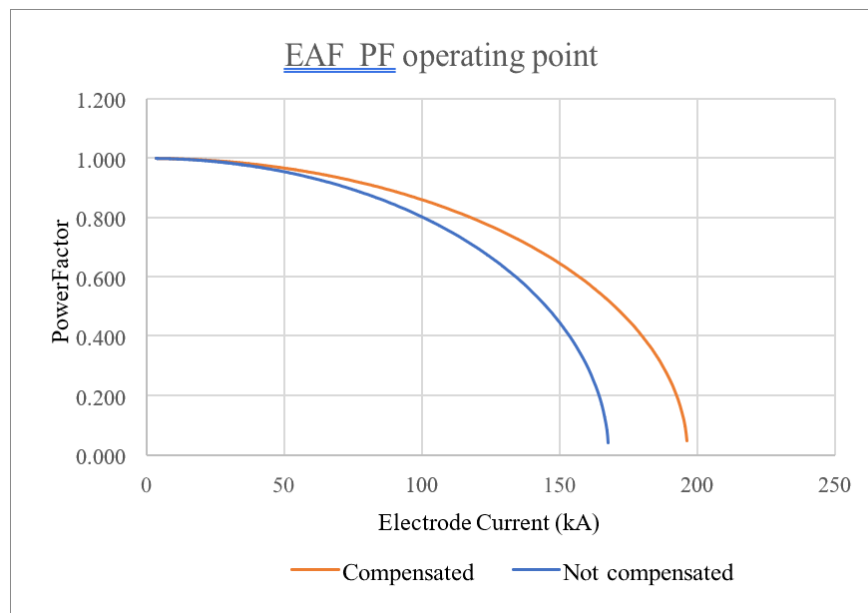

**Figure 5. EAF operating point with/ without SVC Power Factor**

## FURNACE CHARACTERISTICS

JSW Steel operates a 140 MW EAF that incorporates Continuous Preheat Conveyor Charging System technology for continuous steelmaking. AC furnaces like this one benefit from a simpler design and cost efficiency compared to their DC counterparts. However, the AC system can be more variable, potentially leading to greater imbalances and even operation on only two phases. The simpler design of AC furnaces results in lower initial investment and maintenance costs, while the use of AC power allows for a more robust and reliable operation, particularly in handling large batches of scrap metal. This AC furnace uses three graphite electrodes to create an electric arc, providing uniform heat distribution and a stable melting process. The furnace is also equipped with a voltage regulator from a third-party provider, which is responsible for managing the electrical conditions within the furnace.

### **6. Arc length**

Arc length is a crucial parameter in the operation of the EAF at JSW Steel, significantly affecting the melting process and furnace efficiency. Controlling the arc length is essential for maintaining uniform heat distribution and optimal power input, critical for producing high-quality steel. An increase in arc length requires a higher voltage, which can lead to uneven heat distribution and increased power consumption. Conversely, a shorter arc promotes uniform heating and energy efficiency. Arc length variations also impact flicker; a longer arc can cause more significant voltage and current fluctuations, leading to increased flicker in the electrical supply. Precise management of arc length helps minimize the risk of arc instability and flicker, ensuring consistent furnace performance. The furnace's voltage regulator plays a vital role in achieving this level of control, allowing for adjustments in response to varying operational demands.

### **7. Continuous Preheat Conveyor Charging System Operation**

The EAF at JSW Steel utilizes Continuous Preheat Conveyor Charging System technology for a continuous feeding process. Unlike traditional methods where scrap metal is charged intermittently, the continuous charging system allows for the consistent addition of material throughout the steelmaking process. This continuous feeding leads to a more uniform furnace operation, especially during the initial melting stage. As a result, the impact with the SVC system is significant; it can focus on optimizing power input during melting and refining, with less need to manage fluctuations associated with scrap charging. The synergy between the continuous charging system and the SVC system enhances the overall efficiency of the furnace, ensuring steady power availability and a smoother melting process.

## RESULTS

### **7. SVC Power Quality**

The implementation of the new control system has significantly improved power quality parameters at JSW Steel in Mingo, Ohio. Following the upgrade, enhancements were observed in power factor, voltage stability, flicker reduction, and harmonic mitigation, contributing to a more efficient and stable operation of the electric arc furnaces. These results demonstrate the positive impact that a focused upgrade on electrical control can have on power quality and the productivity of industrial operations. The table below shows the results before and after the modernization, highlighting the improvements achieved.

## 8. Arc Stability

The implementation of the SVC system at JSW Steel has had a profound impact on arc stability in the Electric Arc Furnace EAF. Arc stability is crucial for efficient melting and high-quality steel production, as it ensures consistent heat distribution and minimizes disruptions in the melting process.

	Without SVC			With SVC		
	Average	Max 95%	Max 99%	Average	Max 95%	Max 99%
Phase Voltage RMS (V)	77282	78657	78693	78173	78680	79154
Current RMS (A)	187.8	316.5	324.4	127.8	233.8	240.3
<u>Frecuency</u> (Hz)	60.00	60.03	60.03	59.99	60.02	60.03
Power Factor	0.72	0.80	0.81	0.994	0.996	0.996
Phase Voltage THD (%)	0.54	2.66	6.63	0.84	2.16	4.41
Current THD (%)	14.34	48.51	49.62	10.12	26.89	27.15
Flicker PST	0.82	1.72	2.05	0.81	1.41	1.55
Flicker PLT	1.01	1.43	1.47	1.03	1.09	1.12

*Table II. Power Quality Results*

The SVC system provides rapid and precise control of reactive power, which is essential for maintaining voltage stability within the furnace. By compensating for fluctuations in the electrical load, the SVC helps to stabilize the arc, even during the demanding conditions encountered during bucket charging and the introduction of new scrap.

Moreover, the improved arc stability facilitated by the SVC system leads to several operational benefits. It reduces the occurrence of arc fluctuations, which can cause energy losses and damage to furnace components. Additionally, a stable arc contributes to a more uniform temperature within the furnace, enhancing the efficiency of the melting process and the quality of the steel produced. Stability was increased as it flattens and permits to increase the rms voltage, contrary to a more variable voltage where spikes are present they arc to the walls reducing electrode and refractory life.<sup>2</sup>

## 9. EAF Power Factor

JSW Steel has reported a significant improvement in the power factor at the EAF following the implementation of the SVC system. The power factor increased from 0.85 to 0.9, which has led to a notable increase in the available power for the furnace.

The improvement in the power factor is a direct result of the SVC system's ability to provide rapid and precise compensation for reactive power. By reducing the reactive power demand, the SVC system effectively increases the active power available for the melting process. As a consequence, the available power for the EAF has increased from 82 MW to 100 MW.

This increase in available power is crucial for enhancing the efficiency of the melting process. With more power available, the furnace can achieve higher melting rates, increasing overall productivity. Furthermore, the improved power factor contributes to better utilization of the electrical infrastructure, reducing losses and improving the stability of the power supply.

### **10. Power On time**

A relevant operational enhancement achieved at JSW Steel following the SVC system implementation is the reduction in power on time for the EAF. The power on time, which represents the duration of active melting within a heat cycle, has been reduced from 63 minutes to 46 minutes.

This reduction in power on time is a direct consequence of the enhanced power factor and increased available power resulting from the SVC system's operation. With more power available for the melting process, the furnace can achieve higher melting rates, leading to shorter cycle times. This not only increases the overall productivity of the steelmaking operations but also reduces energy consumption per ton of steel produced, leading to cost savings and a lower environmental impact.

### **11. Electrode Consumption & Refractory Lifetime**

This upgrade also has significantly influenced electrode consumption and refractory lifetime in the EAF.

The SVC provides the flexibility to manage arc length more effectively, allowing for a stable and higher arc voltage. Operating with a higher voltage and consequently a longer arc length leads to a lower current requirement, which in turn reduces electrode consumption.

The wear rate of the refractory lining is proportional to both the arc length and the active power.

While it may seem contradictory to reduce electrode consumption and refractory wear simultaneously, the improvement in voltage stability provided by the SVC allows for greater flexibility in operating at an optimal point for both objectives. By effectively managing the arc length, the SVC enables JSW Steel to strike a balance between minimizing electrode wear and reducing refractory wear, ultimately enhancing overall furnace efficiency and longevity.

These improvements not only lead to significant cost savings but also enhance the sustainability of the steelmaking process by reducing material usage and energy consumption.

### **12. Production Cycles Optimization**

The optimization of key operational parameters, such as reduced power-on time, improved electrode and refractory usage, and decreased wear on the entire system, has had a compounding effect on the productivity of the EAF at JSW Steel. The enhancements brought about by the SVC system have resulted in more available system time and optimized production cycle sequences. This increased operational efficiency allows for better synchronization with downstream processes, like the continuous caster, further streamlining the overall production flow.

The cumulative impact of these improvements is a significant increase in productivity. With the furnace operating more smoothly and consistently, JSW Steel can produce more steel in less time, leading to higher throughput and better utilization of resources.

## CONCLUSIONS

In conclusion, the upgrade of the SVC system at JSW Steel successfully met its objectives of increasing SVC availability, improving power quality parameters such as power factor, current unbalance, voltage variations, flicker, and total harmonic distortion (THD), along with enhanced functionalities provided by a more modern digital control system with advanced diagnostics and connectivity.

Additionally, to the power quality and maintainability improvements, the upgrade has led to remarkable improvements in the operational efficiency of the Electric Arc Furnace (EAF).

- The power-on time has been significantly reduced from 63 minutes to 46 minutes,
- The available power for the furnace has increased from 82 MW to 100 MW,
- Power factor at EAF increased from 0.85 to 0.9.

The optimization of key operational parameters, such as electrode and refractory usage, has had a compounding effect on productivity. The enhancements brought about by the SVC system have resulted in more available system time and optimized production cycle sequences, enabling better synchronization with downstream processes, and further streamlining the overall production flow.

The cumulative impact of these improvements is a substantial increase in productivity. With the furnace operating more smoothly and consistently, JSW Steel can produce more steel in less time, leading to higher throughput and better utilization of resources. The upgrade has not only resulted in significant cost savings but also increased sustainability by reducing material usage and energy consumption, demonstrating the value of targeted upgrades to electrical control systems in industrial processes.

## REFERENCES

1. J. Haros, A. Mariscal, E. Martínez, J.L. Pepe, B. Sainz, "Efficient And Reliable Method To Upgrade Static Var Compensator (SVC) Control Reusing The Solid-State Valves," AISTech 2022 - The Iron & Steel Technology Conference and Exposition, 6–9 May 2022, Pittsburgh, Pennsylvania, USA, pp. 1-3.
2. IEEE Standards Association, "IEEE Recommended Practice and Requirements for Harmonic Control in Electric Power Systems," IEEE Standard 519-2014, 11 June 2014, link.
3. T.J.E. Miller, "Reactive Power Control in Electric Systems," John Wiley & Sons, Inc., New York, NY, USA, 1982.
4. Energies, "Selection of C-Type Filters for Reactive Power Compensation and Filtration of Higher Harmonics Injected into the Transmission System by Arc Furnaces," Energies 2020, 13(9), 2330